

HYDRAULIC BREAKER

Parts Manual

PMM17CBENG.814

Serial No.

BT17C0005-UP



TABLE OF CONTENTS

1. Housing unit	4
2. Impact unit	6
3. Impact unit, continued.	8
4. Seal set	10
5. Service kit	12
6. Service kit 2	13
7. Manual greasing	14
8. Greasing device kit	16
9. Greasing device.	18
10. Service kit for greasing device RG540 series	20

GENUINE BRETEC SPARE PARTS

Bretec genuine spare parts are designed and manufactured by using the latest technological knowledge and engineering skills. Bretec spare parts are made of the best available materials with the most advanced manufacturing techniques.

It is important that you use only genuine Bretec spare parts, to ensure easy operation, maintenance and repair of the product. Please note that eventual warranty claims will be handled only if you have used genuine Bretec parts in your Bretec product.

LOCATION OF THE SERIAL NUMBER

It's important to make correct reference to the serial number of the product when ordering spare parts. Identification of serial number is the only proper means of maintaining and identifying parts for a specific product. The location of equipment serial number is pointed in "Operation and maintenance" manual.

SPARE PART ORDERS

Quick spare part deliveries are secured by exact orders.

Required information:

- Name of customer and contact person
 - Order number (when available)
 - Delivery address
 - Mode of delivery (air mail etc.)
 - Required delivery date
 - Invoicing address
 - Model and serial number of the product
 - Name, number and required amount of spare parts
-

1. Parts

1. HOUSING UNIT

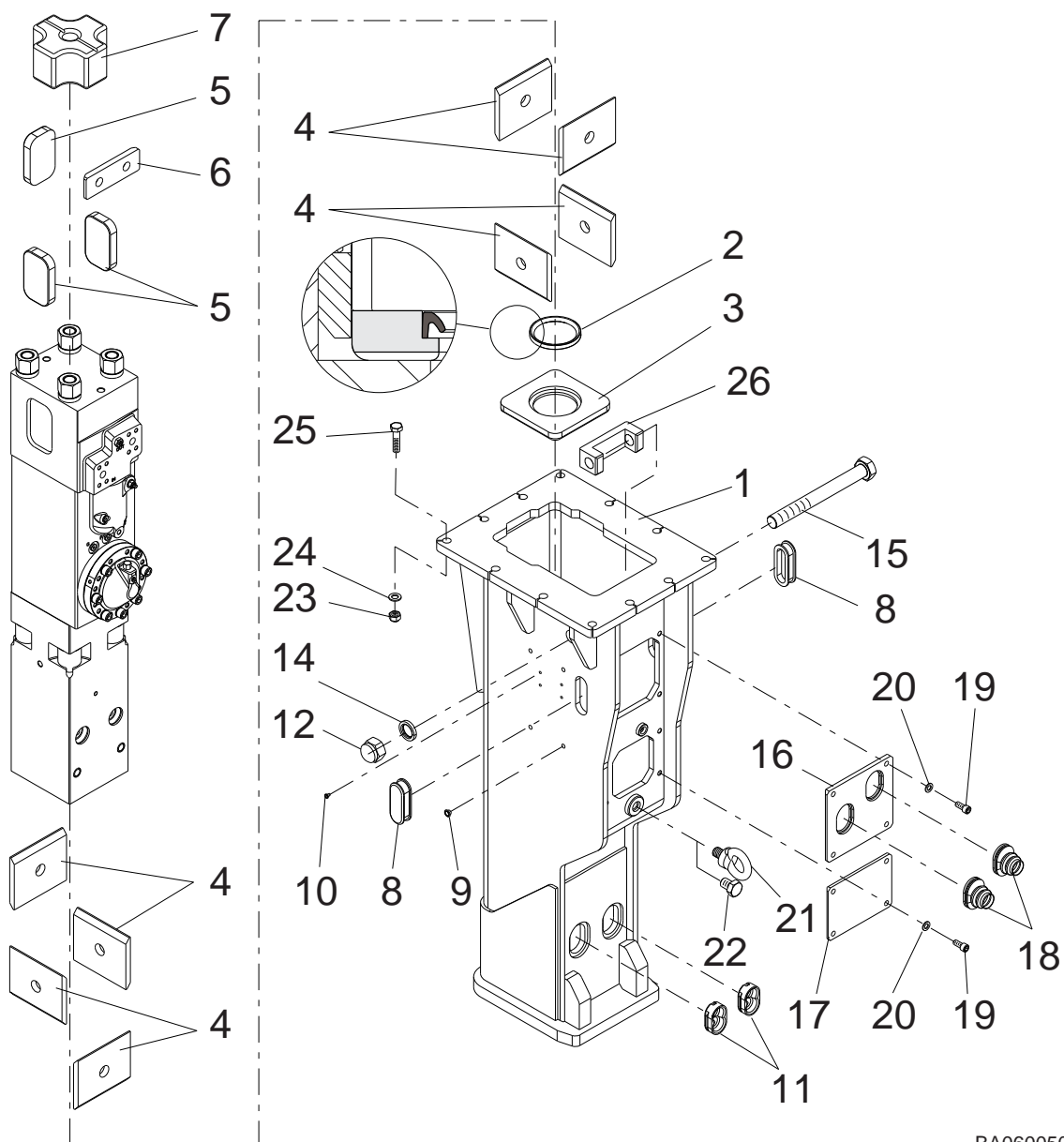

BA060050

Item	Description	Part no.	Specification	Note	Qty
1	Housing (incl. part 26)	172642			1
2	Seal	171318			1
3	Pad	171969			1
4	Wear plate	171968			8
5	Wear plate	171967			3
6	Pad	167678			1
7	Buffer	167671			1
8	Rubber plug	167042			2
9	Rubber plug	953291			4
10	Rubber plug	953332			4
11	Rubber plug	169940			2

Item	Description	Part no.	Specification	Note	Qty
12	Nut	953629	M30x2-4 DIN 1587		1
14	Lock washer	90598	NL30T NORD-LOCK		1
15	Hex. screw	954336	M30x2x350-4.6 ISO 4014		1
16	Shield plate	171984			1
17	Cover	171985			1
18	Hose guide	167056			2
19	Hex. socket screw	902895	M16x35-8.8 ISO 4762		8
20	Washer	952541	M16 ISO 7089		8
21	Lifting eye	90605	M24 DIN 580		1
22	Hex. screw	900025	M24x35-8.8 ISO 4017		1
23	Hex. screw	90589	M24x110-12.9 ISO 4014		12
24	Washer	90511	25 ISO 7416		12
25	Lock nut	90507	M24-12 DIN 985		12
26	Spacer	171972			1
201	Label set (incl. part 202)	171946			1
202	Safety label set	169400	english		1

2. IMPACT UNIT

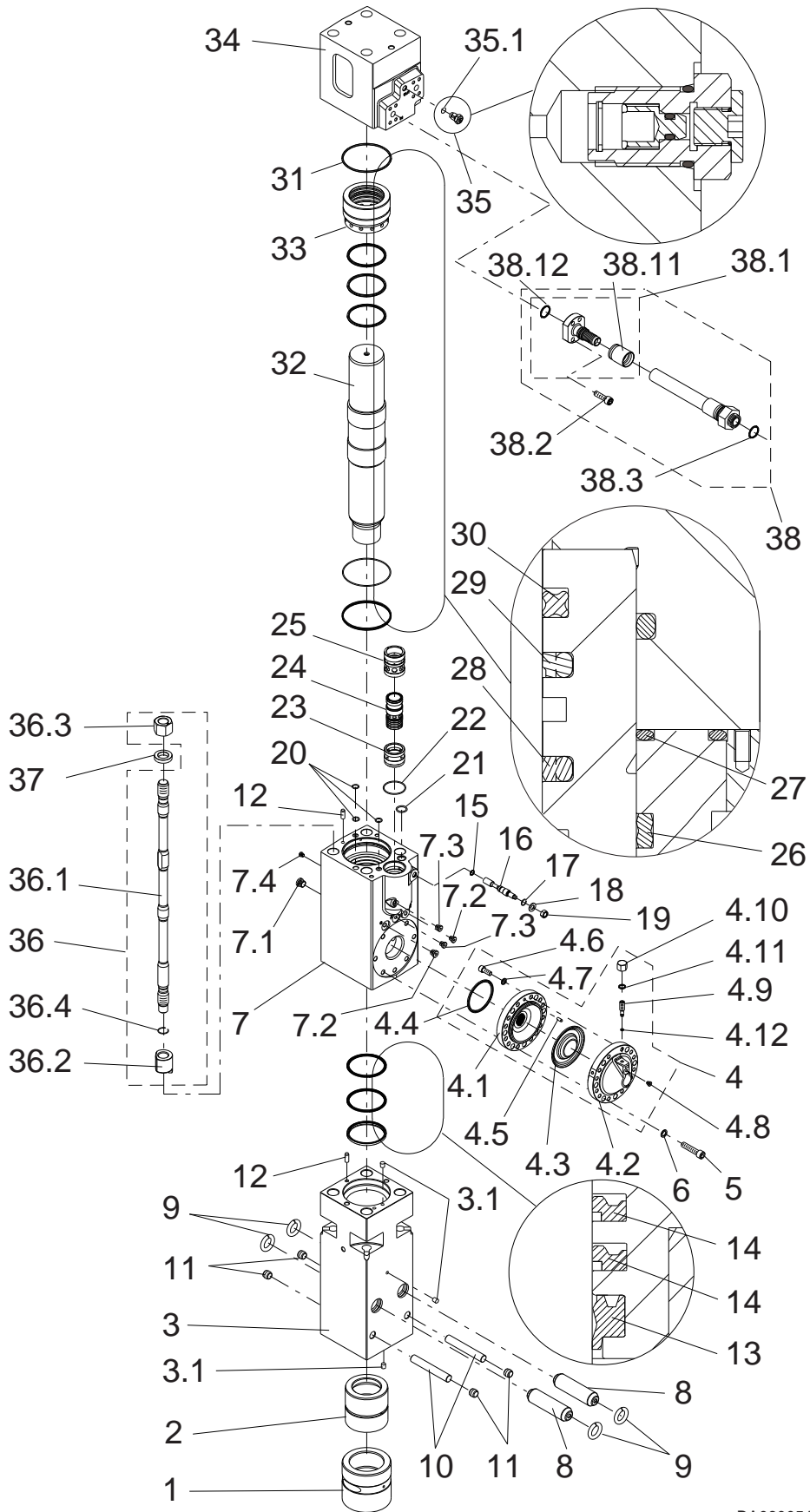

BA060051

Item	Description	Part no.	Specification	Note	Qty
1	Lower tool bushing	169529			1
2	Upper tool bushing	169530			1
3	Front head (incl. part 3.1)	169525			1
3.1	Plug	111399			3
4	Accumulator (incl. parts 4.1-4.12)	169535			1
4.1	Accumulator bottom	169536			1
4.2	Accumulator cover	169534			1
4.3	Membrane	300688			1
4.4	Seal	41357		*	1
4.5	Parallel pin	90304			1
4.6	Hex. socket screw	90593	M14x45-8.8 ISO 4762		12
4.7	Lock washer	901310	M14 NORD-LOCK		12
4.8	Flange plug	953463	M10x1		1
4.9	Spool	166907			1
4.10	Nut	166908	M24x1.5 ISO 4032		1
4.11	O-ring	94035		*	1
4.12	O-ring	954132		*	1
5	Hex. socket screw	900004	M16x90-8.8 ISO 4762		7
6	Lock washer	90597	M16 NORD-LOCK		7
7	Cylinder (incl. parts 7.1-7.4)	172053			1
7.1	Flange plug	90401	R3/4		1
7.2	Flange plug	90444	R3/8		2
7.3	Flange plug	90403	R1/4		2
7.4	Flange plug	93203	R1/8		1
8	Tool retaining pin	169604			2
9	Rubber ring	169725			4
10	Retaining pin	400323			2
11	Rubber plug	104876			4
12	Parallel pin	90308			2
13	Wiper	952636		*	1
14	Seal	952579		*	2
15	O-ring	94035		*	1
16	Spool	172060			1
17	Spring ring	954331	B22 DIN 7993		1
18	Lock washer	953285	NL16SP NORD-LOCK		1
19	Nut	91000	M16-8 ISO 4032		1
	*) Are included in seal set				

3. IMPACT UNIT, CONTINUED

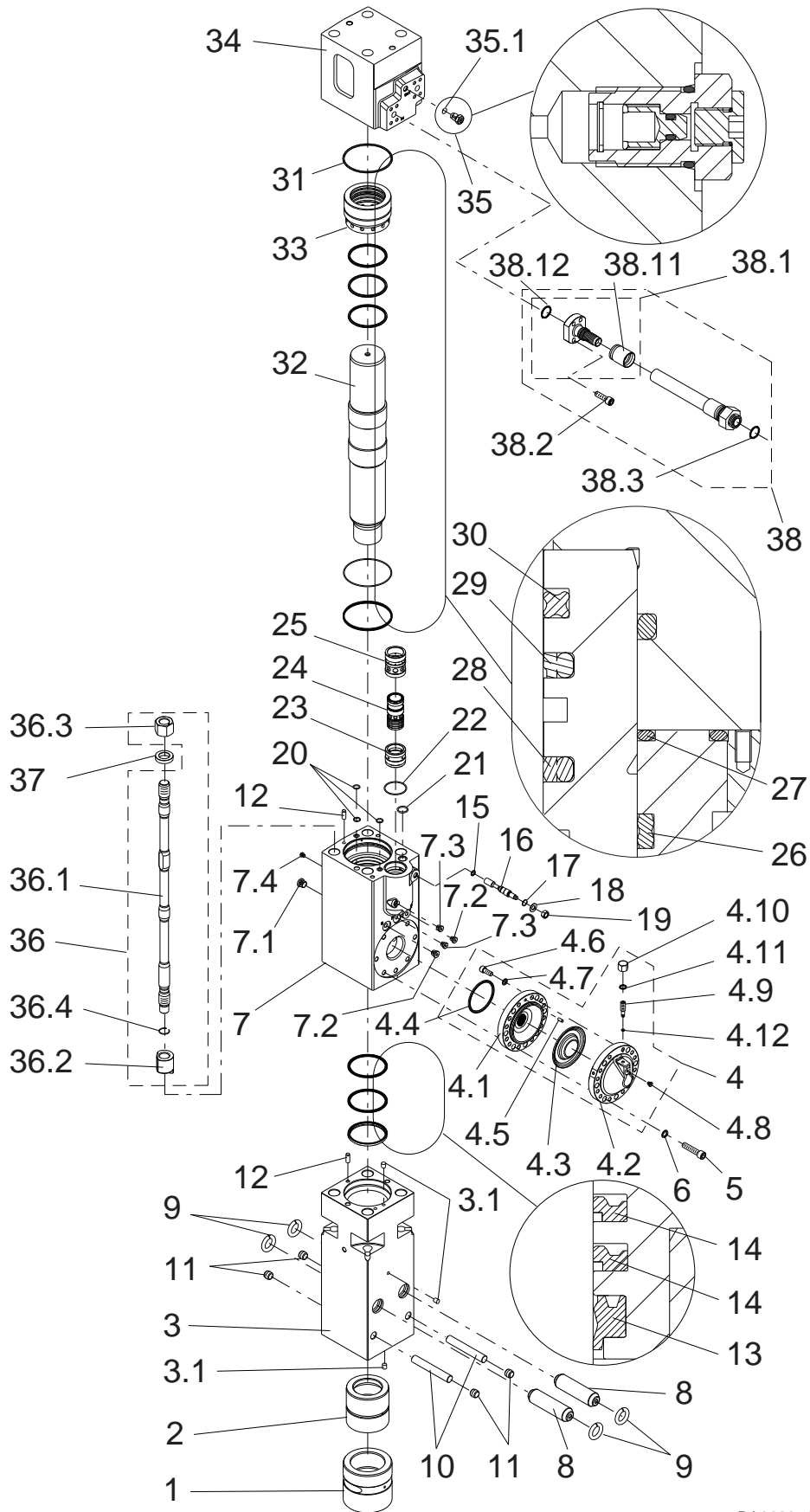

BA060051

Item	Description	Part no.	Specification	Note	Qty
20	O-ring	953950		*	3
21	O-ring	954009		*	1
22	O-ring	953953		*	1
23	Sliding ring	172395			1
24	Distributor	172394			1
25	Steering ring	172033			1
26	Seal	954047		*	1
27	O-ring	954008		*	1
28	Seal	954010		*	1
29	Seal	954011		*	1
30	Seal	954012		*	1
31	O-ring	90002		*	1
32	Piston	171383			1
33	Seal carrier	169531			1
34	Back head	169504			1
35	Accumulator filling plug (incl. parts 35.1)	165780			1
35.1	O-ring	901135	D17	*	1
36	Tie rod (incl. parts 36.1-36.3)	K50M17			4
36.1	Tie rod				1
36.2	Nut				1
36.3	Tie rod nut				1
36.4	Spring ring				1
37	Washer	169544			4
38	Hose assembly (incl. parts 38.1-38.3)	952691			2
38.1	Hose coupling (incl. parts 38.11-38.12)	400637			1
38.11	Bushing	101335			1
38.12	O-ring	90010	D33		1
38.2	Hex. socket screw	90564	M12x40-8.8 ISO 4762		4
38.3	O-ring	N/A	D24		1
	*) Are included in seal set				

4. SEAL SET

Seal set 172658

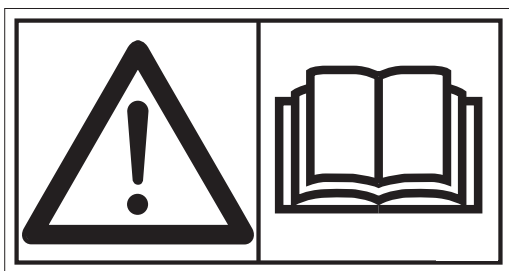
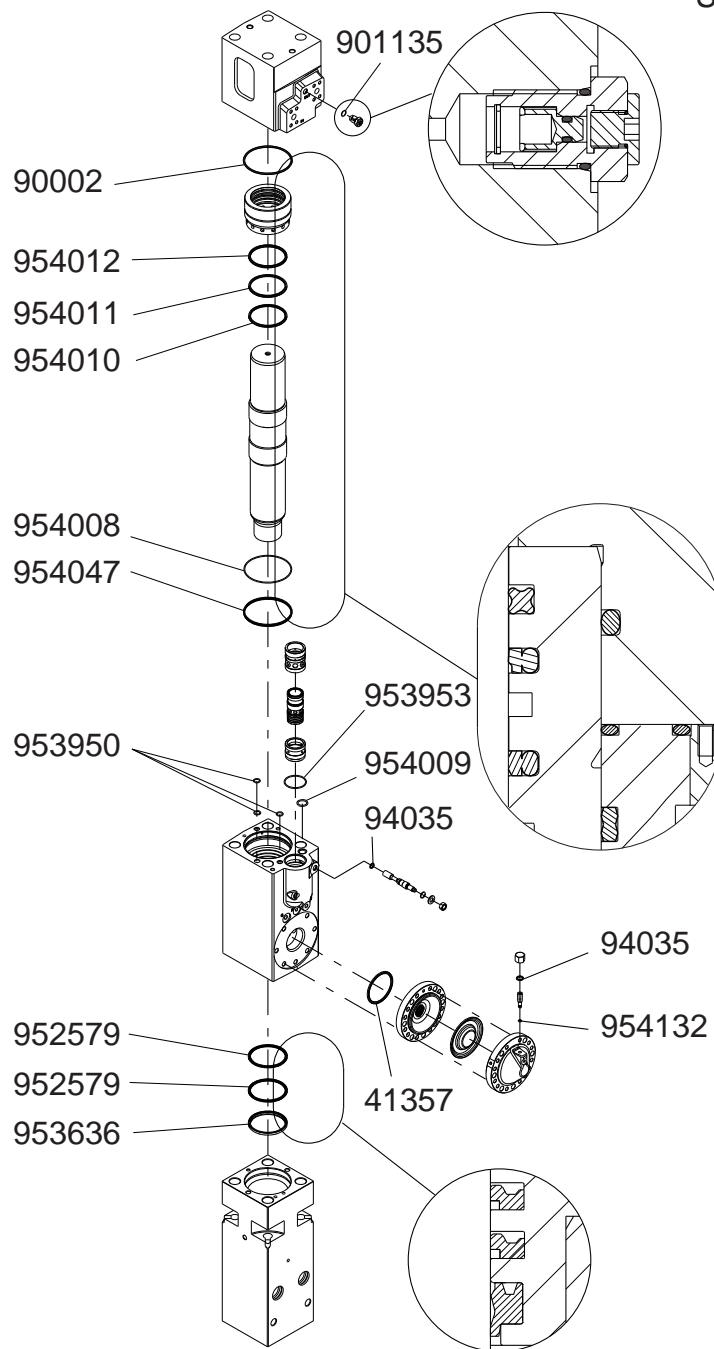

This summary only indicates the position of the seals. It must NOT be used as assembly instruction. Read the manual.

BA060052

Item	Description	Part no.	Specification	Note	Qty
Kit	Seal set (incl. parts 1-15)	172658			1
1	Seal	41357			1
2	O-ring	94035			2
3	O-ring	954132			1
4	Wiper	952636			1
5	Seal	952579			2
6	O-ring	953950			3
7	O-ring	954009			1
8	O-ring	953953			1
9	Seal	954047			1
10	O-ring	954008			1
11	Seal	954010			1
12	Seal	954011			1
13	Seal	954012			1
14	O-ring	90002			1
15	O-ring	901135	D17		1

5. SERVICE KIT

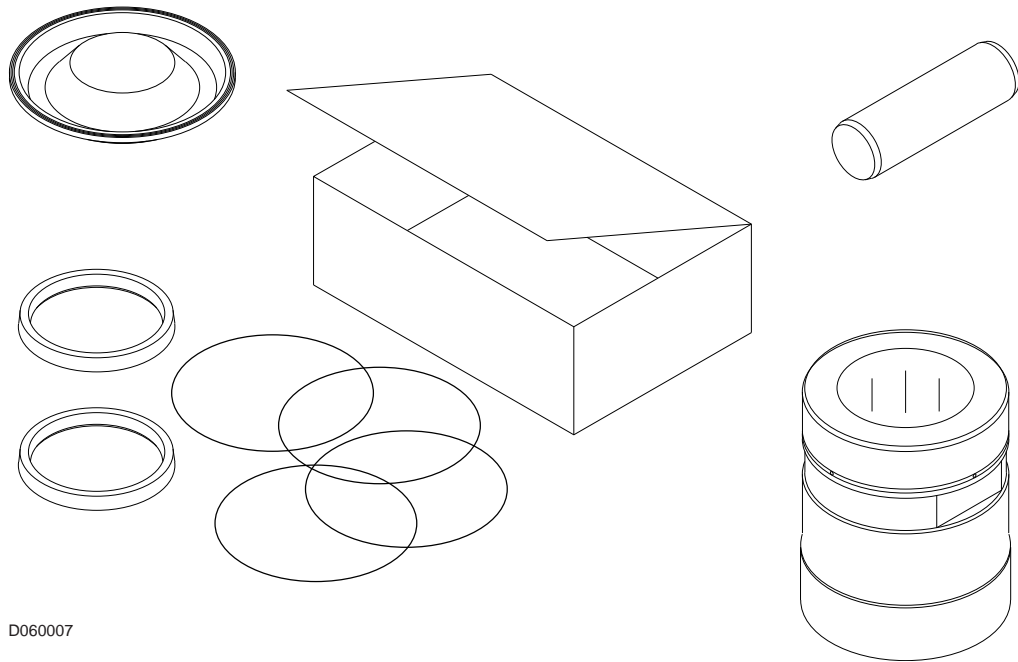

D060007

Item	Description	Part no.	Specification	Note	Qty
Kit	Servicekit (incl. parts 1 - 4)	K10M17C			1
1	Lower tool bushing	169529			1
2	Membrane	300688			1
3	Tool retaining pin	169604			2
4	Seal set	172658			1

6. SERVICE KIT 2

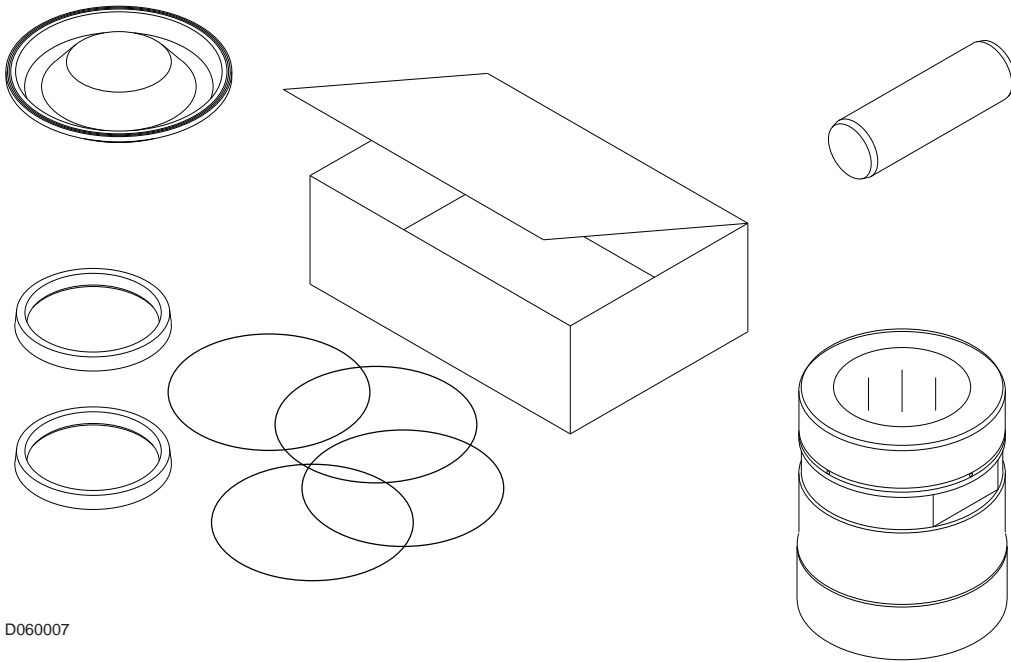

D060007

Item	Description	Part no.	Specification	Note	Qty
Kit	Servicekit (incl. parts 1 - 6)	K20M17C			1
1	Pad	171969			1
2	Wear plate	171968			8
3	Wear plate	171967			3
4	Pad	167678			1
5	Buffer	167671			1
6	Upper tool bushing	169530			1

7. MANUAL GREASING

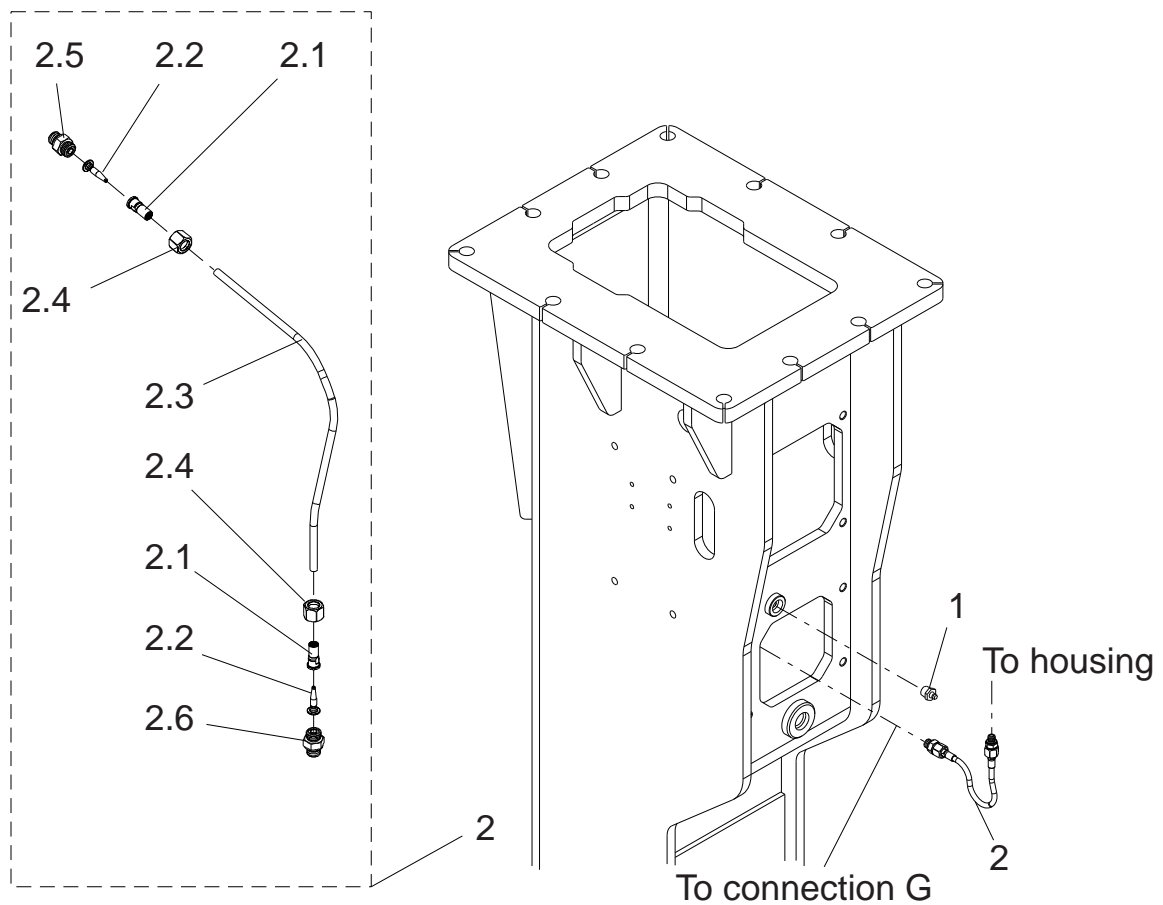

BA060049

Item	Description	Part no.	Specification	Note	Qty
1	Grease nipple	90200			1
2	Hose assembly (incl. parts 2.1-2.7)	170715			1
2.1	Sleeve	153035			2
2.2	Insert	153036			2
2.3	Hose	954144			1
2.4	Nut	951296			2
2.5	Connector	951295	BSPP 3/8		1
2.6	Connector	951294	BSPP 1/4		1

8. GREASING DEVICE KIT

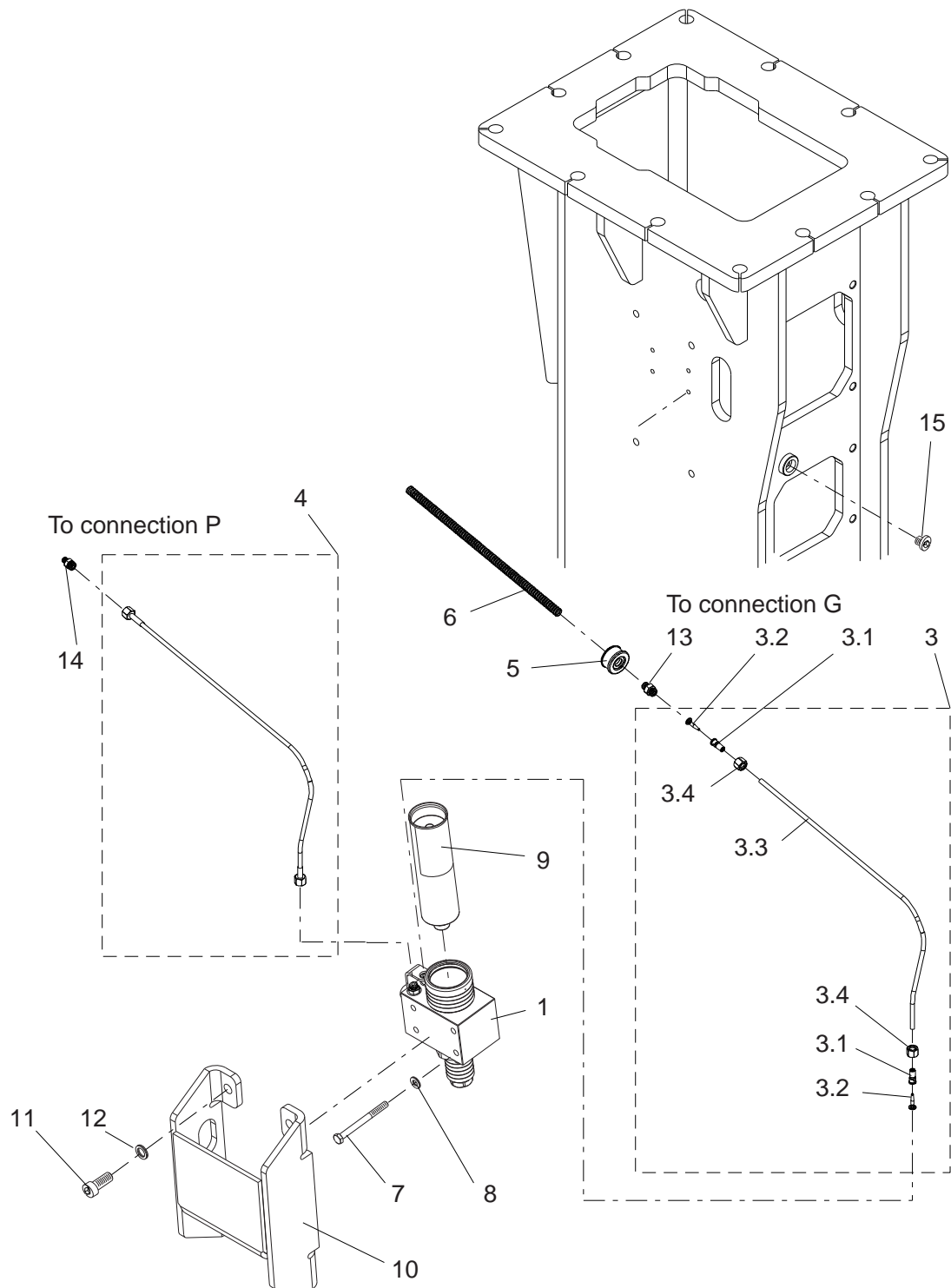

BA060047

Item	Description	Part no.	Specification	Note	Qty
Kit	Greasing device retrofit kit (incl. parts 1-14)	172355			1
1	Greasing device RG541	953344			1
3	Hose assembly (incl. parts 3.1-3.4)	171170			1
3.1	Sleeve	153035			2
3.2	Insert	153036			2
3.3	Hose	954195			1
3.4	Nut	951296			2
4	Hose assembly	954332			1
5	Rubber bushing	158147			1
6	Shield	952093			1
7	Hex. screw	953794	M10x110-8.8 ISO 4014		4
8	Lock washer	953503	M10 NL10sp NORD-LOCK		4
9	Grease cartridge	954352	Special tool grease, Greasing device cartridge. Greasing device cartridges are also sold in boxes of 24.		1
10	Shield	172029			1
11	Hex. socket screw	902895	M16x35-8.8 ISO 44762		4
12	Lock washer	90597	M16 NORD-LOCK		4
13	Connector	951295	BSPP 3/8		1
14	Connector	951294	BSPP 1/4		1
15	Flange plug	90403	R1/4		1

9. GREASING DEVICE

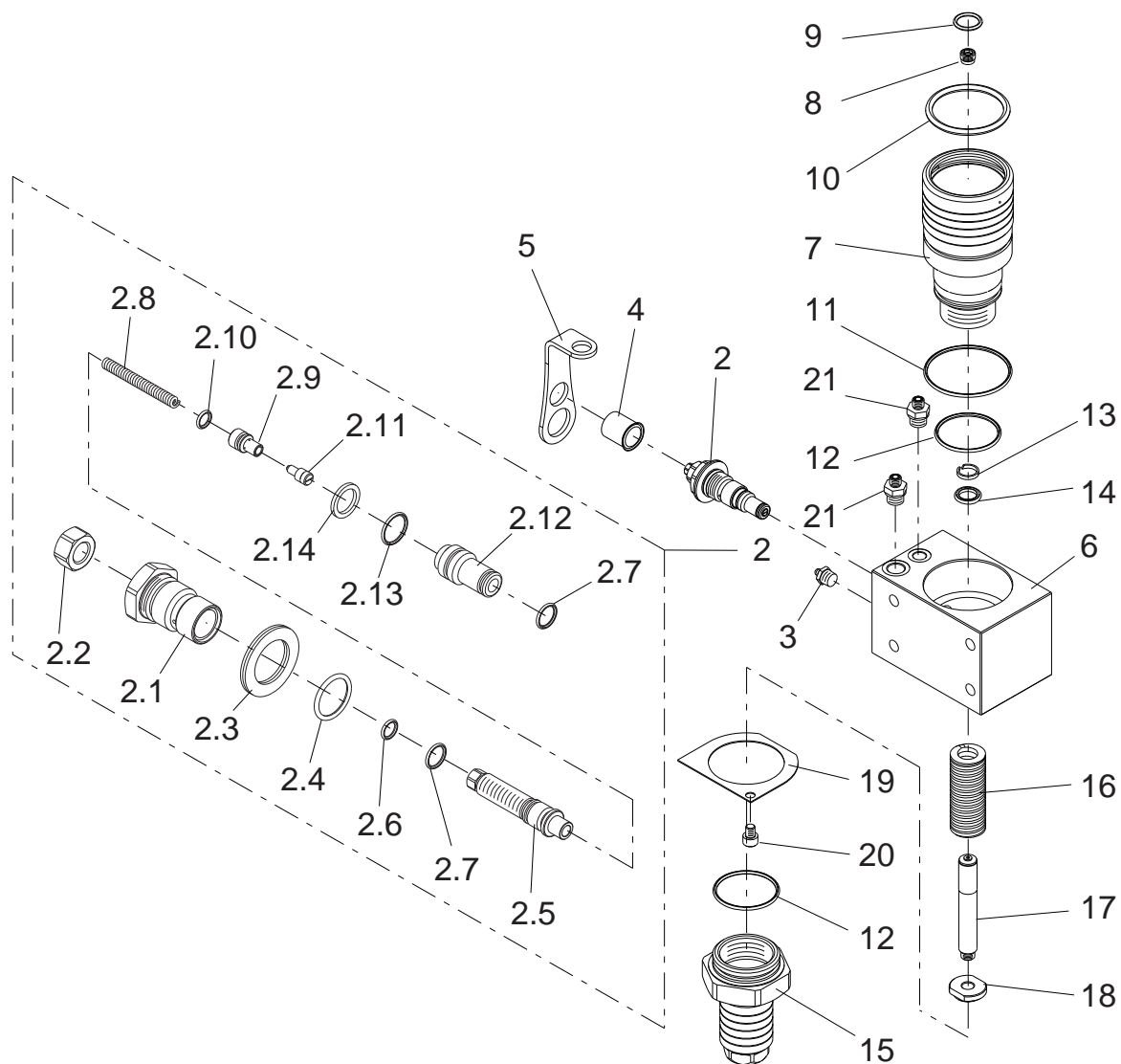

BA060046

Item	Description	Part no.	Specification	Note	Qty
1	Greasing device RG541 (incl. parts 2-21)	953344			1
2	Doser (incl. parts 2.1-2.14)	953305			1
2.1	Plug	953318			1
2.2	Nut	953330	M12x1 DIN 934		1
2.3	Lock washer	91038	M24 NORD-LOCK	*	1
2.4	O-ring	953325	D21	*	1
2.5	Adjusting screw	953317			1
2.6	O-ring	953326	D8	*	1
2.7	O-ring	953324	D11	*	2
2.8	Spring	953331		*	1
2.9	Piston	953319			1
2.10	O-ring	953322	D7	*	1
2.11	Piston	953329		*	1

Item	Description	Part no.	Specification	Note	Qty
2.12	Body	953320			1
2.13	O-ring	953323	D15	*	1
2.14	Shim plate	953321		*	1
3	Grease nipple	90200	BSP 1/4	*	1
4	Plug	953303		*	1
5	Locking plate	953302		*	1
6	Body	953310			1
7	Cartridge holder	953309			1
8	Check valve	951767			1
9	O-ring	951416	D19	*	1
10	O-ring	951453	D62	*	1
11	O-ring	953300	D71	*	1
12	O-ring	953301	D52	*	2
13	Guide ring	950272		*	1
14	Seal	953299		*	1
15	Spring housing	953308			1
16	Spring	950257			1
17	Piston	953307			1
18	Nut	953306			1
19	Lock plate	951410		*	1
20	Hex. socket screw	951421	M8x10-8.8 ISO 4762	*	1
21	Connector	951294	BSPP 1/4		2
kit	Seal set for greasing device	953385			1
	*) Are included in seal set for greasing device				

10. SERVICE KIT FOR GREASING DEVICE RG540 SERIES

Service kit 953385

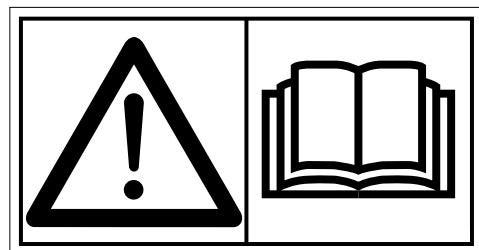
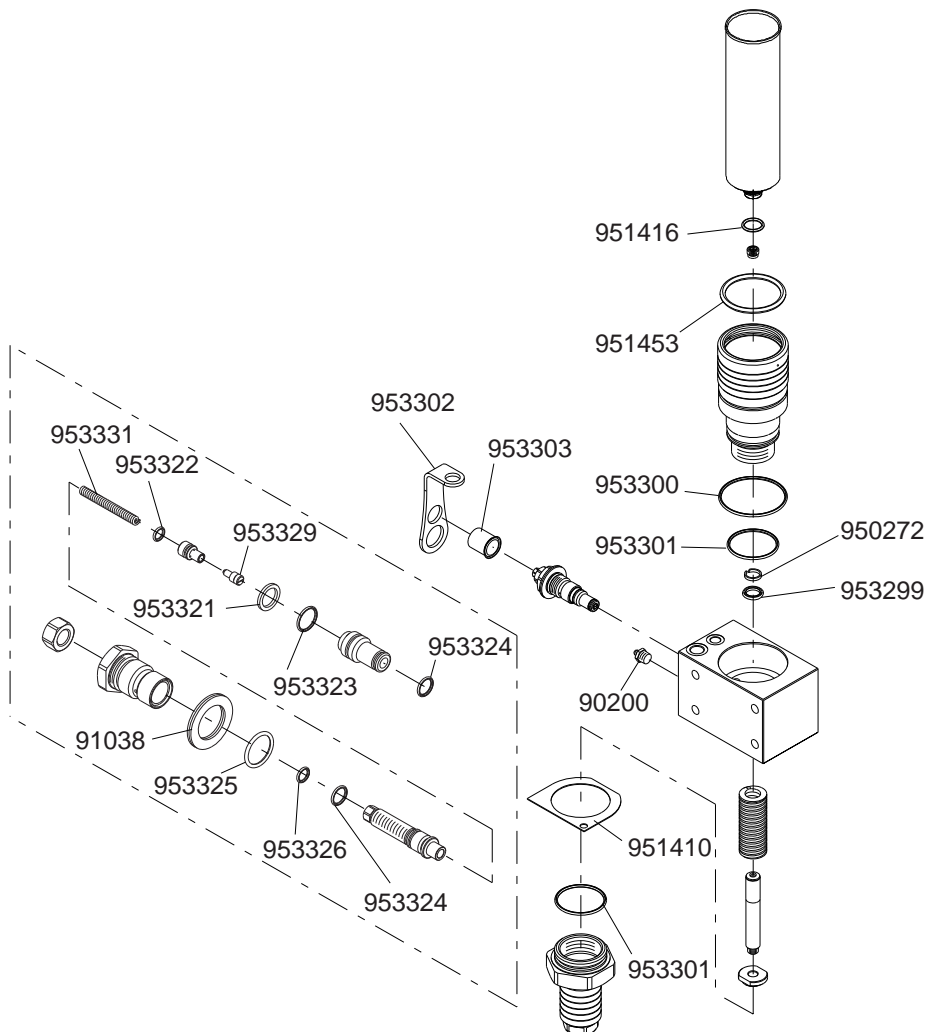

This summary only indicates the position of the seals. It must NOT be used as assembly instruction. Read the manual.

BA060038

Item	Description	Part no.	Specification	Note	Qty
Kit	Service kit for greasing device (incl. parts 1-19)	953385			1
1	Lock plate	951410			1
2	Plug	953303			2
3	Guide ring	950272			1
4	Seal	953299			1
5	O-ring	953300	D71		1
6	O-ring	951453	D62		1
7	O-ring	953301	D52		2
8	O-ring	951416	D19		1
9	O-ring	953326	D8		2
10	O-ring	953325	D21		2
11	O-ring	953324	D11		4
12	O-ring	953323	D15		2
13	O-ring	953322	D7		2
14	Shim plate	953321			2
15	Spring	953331			2
16	Piston	953329			2
17	Lock washer	91038	M24 NORD-LOCK		2
18	Grease nipple	90200	R1/4		2
19	Locking plate	953302			2
	Service kit for greasing device are not included in hammers seal set.				



© 2014 Sandvik
All rights reserved.

9-28-14098-45-8-140
12-28-14098-24-16-371

www.bretec.com